

Placement concerns for "Gathering Lore"

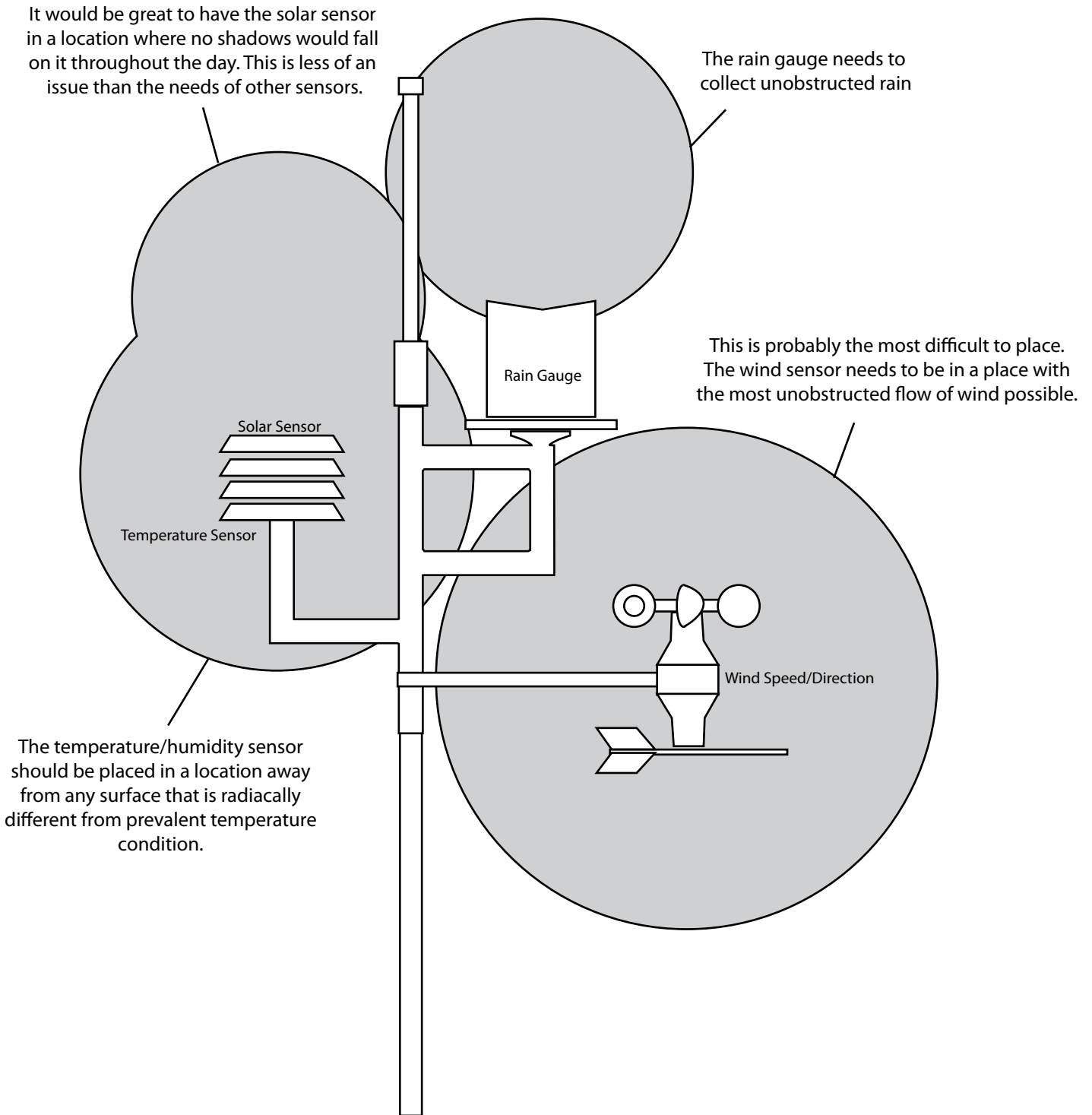

Three possible mounting options for "Gathering Lore"

1. Attach to an existing pole/post. The unit is fairly light - 20/25 lbs. and it should be easy to secure with hose clamps.

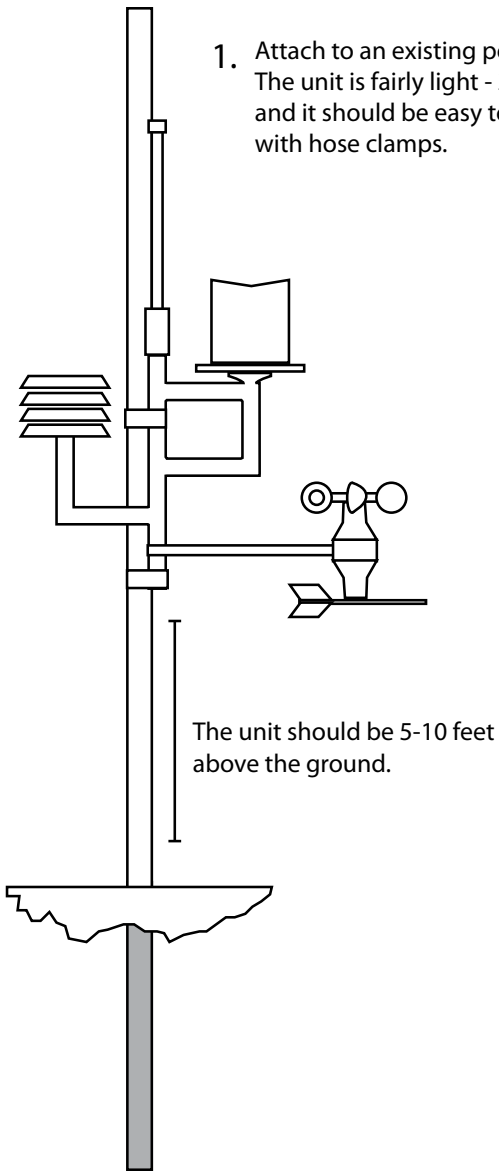

The unit should be 5-10 feet above the ground.

2. Install a new pole in the ground. The unit is not very heavy, but would need to be attached to a structurally sound post - especially if free standing.

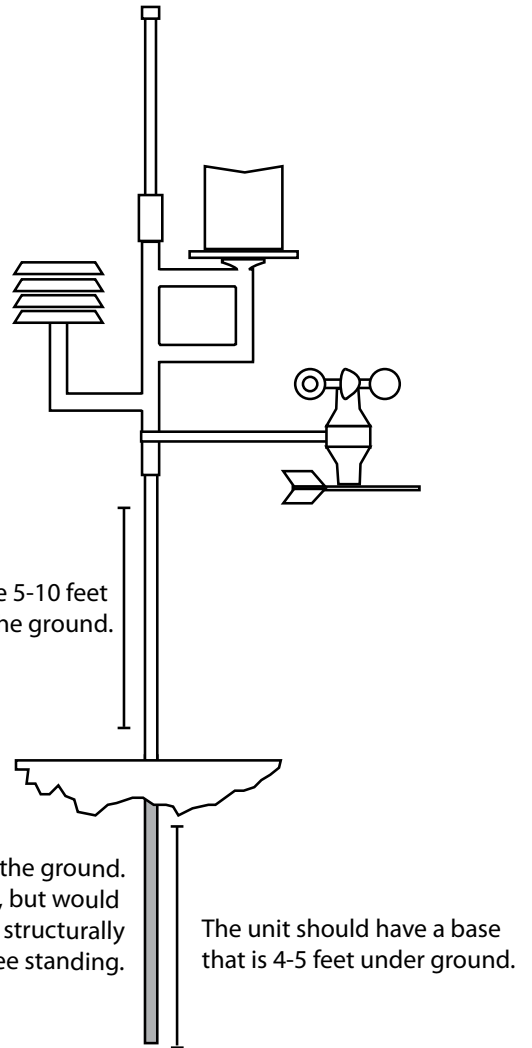

3. Attach to an existing structure. The unit is made from PVC pipe and can easily be made to attach to a vertical surface.

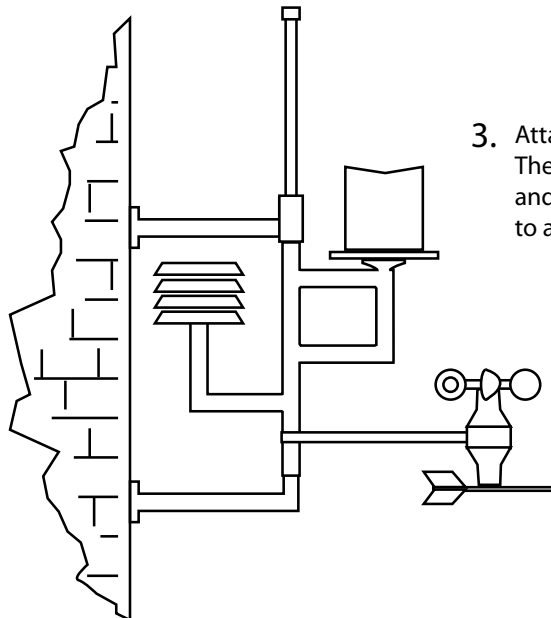

Wiring for "Gathering Lore" (non-schematic)

